

# New Drive System with Synchronous Motor: “SANMOTION”G

Shigeki Satou   Yoshinori Kimura   Shigenori Miyairi   Koji Nakatake

## 1. Introduction

To control the speed of a synchronous motor, an inverter is usually added. In this case, only torque proportional to the output voltage of the inverter can be output in the frequency band below the rated frequency, although the rated torque is obtained in proximity of the rated frequency (about 60Hz). A normal inverter will, of course, offset the lack of torque in the band lower than the rated frequency by adding a torque boost function. However, because this function was a control intended for use with induction motors, it could not sufficiently bring out the features of SANYO DENKI's synchronous motor. SANMOTION G is a new drive system for the synchronous motor, which can obtain a flat torque characteristic even in the band below the rated frequency. It is designed to be easier to use in several applications. The synchronous motor and the new drive system are explained below.

## 2. Background of the Development

To date, when an inverter equipment for running induction motor was used for speed control of the synchronous motor, only the drooping torque characteristic curve with a peak in the proximity of the rated frequency could be obtained. However, we have understood that many applications in variable-speed motor drive need a flat torque characteristic even in the band below the rated frequency, and more high Rated Speed. This required development of a new drive system, which has more high Rated Speed and obtains the constant torque characteristic.

## 3. Outlines of Synchronous motor and Driver

We have developed a system that is able to obtain stable high torque from a low-speed region to a high-speed region. The basic specifications are described below.

### 3.1 Basic Specifications

Rotating Speed of Motor:

Standard Type: 0-72min<sup>-1</sup>

High Speed Type: 0-120min<sup>-1</sup>

Motor Rated Torque:

Standard Type: 0.9/1.3/2/3.7 [N/m](4Types)

High Speed Type: 1/1.8/2.2/2.9[N/m](4Types)

Driver Series:

GH1Driver: GH1B012Z (1Type)



Fig. 1 “SANMOTION”G Synchronous Motor



Fig. 2 “SANMOTION”G Driver

**Table 1 Basic Specifications**

Motor Type	103M8831 -2540	103M8332 -2540	103M8333 -2540	103M89332 -2540	103M8331 -3540	103M8332 -3540	103M8333 -3540	103M89332 -3540
Motor Rated Frequency[Hz]	50/60				100			
Motor Rated Speed[ $\text{min}^{-1}$ ]	60/72				120			
Driver Rated Frequency [Hz]	50				140			
Maximum Frequency[Hz]	60				140			
Rated Torque [N/m]	0.9	1.3	2	3.7	1	1.8	2.2	2.9
Motor Rated Voltage [Vac]	240				155		160	200
Motor Rated Current[A]	0.11	0.13	0.17	0.22	0.28	0.42	0.45	0.5
Motor Weight [Kg]	1.55	2.7	3.9	7.4	1.55	2.7	3.9	7.4
Driver Model	GH1B012Z**							
Rated Input AC Voltage	AC200~240V single phase / 3 phase 50/60Hz							
Driver Rated Output Current [A]	1.4							

### 3.2 Driver Specification

Item	Specifications	
Model	GH1B012□◇◇	
General Spec.	Control Function	Speed Control
	Ambient Temp.	- 10~40°C (Carrier Frequency Up to 5kHz) - 10~50°C (When Output Is Decreased)
	Storage Temp.	- 20~65°C
	Humidity	20~90% RH
	Vibration	5.9m./s <sup>2</sup> (0.6G), 10~55Hz z
	IP Rating	IP20
Control	Controlling Method	Sine Wave PWM control
	Output Frequency Range	0.1~400Hz z
	Frequency Accuracy	Digital Command $\pm 0.01\%$ , Analog Command $\pm 0.2\%$ ( $25 \pm 10^\circ\text{C}$ ) relative to maximum frequency
	Frequency Setting Resolution	Digital Setting : 0.1Hz z Analog Setting : Maximum Frequency/1000
	Voltage/Frequency Characteristics	V/f Characteristic (constant Torque)
	Overload Current Rating	150%, 1 min.
	Acceleration, Deceleration Time	0.01~3000 sec. (Linear, S-curve), Secondly Acceleration and Deceleration Setting Available
Carrier Frequency Changeable Band	2.0-14.0kHz	
Frequency Command Method	Frequency Setting	Setting with Attached Volume Setting with Up/Down Key 2W 1k $\Omega$ -2k $\Omega$ variable Resistance DC0-10V (Input Impedance 10k $\Omega$ ), 4-20mA (Input Impedance 250 $\Omega$ ), Communication via RS-485 Port (Modbus-RTU)
Operation Command Method	Forward / Reverse Start/Stop	Start/Stop with intelligent input or Key Start/Stop with RS-485 Communication (Modbus-RTU)
Input Signal	Intelligent Input (Selectable)	Forward Command, Reverse Command, multi-Speed Command, Reset Input, Current Input Selection, restart after power failure prevention Function, external Trip, Forced Operation, 3 Wire Function (start, stop, forward/reverse), Free Run Stop Command, Jogging Command, 2 Stage Acceleration/Deceleration Command, external DC Braking, Remote Control Function (speed up/down) PID Valid/Invalid, PID Deviation Clear, Thermistor Input, Up Down Clear, Soft Lock Command
	Intelligent Output (Selectable)	signal during operation command, output at the time of reaching constant speed, output over set frequency, Overload Warning Signal, PID Excessive Deviation Signal, Alarm Signal, Analog Input Disconnection Detection Signal
Output Signal	Frequency Monitor	Select frequency signal and current signal (DC0-10V, 1mA)
	Intelligent Relay Output	Output the intelligent output and its function signal by relay (1c Contact)

### 4. Features

The main features of this product are as follows.

#### 4.1 Main Features

- Open-Loop control and sensorless control
- Flat high torque characteristic up to the rated speed
- Improved rated rotating speed (120 $\text{min}^{-1}$ )
- Occurrence of position retention function
- A single driver can synchronize and control multiple motors

#### 4.2 Open-Loop control and Sensorless Control

Our synchronous motor is able to rotate the motor at an accurate synchronous speed to the command frequency without requiring a sensor, because it is designed based on the stepping motor. Therefore, in compared with AC servo system, manufacture cost of a motor is made at a low cost, and can also reduce the cost concerning wiring in a field.

#### 4.3 Flat High Torque Characteristic up to The Rated Speed

With conventional combinations of synchronous motor and inverter equipment, control with the constant V/f ratio was the usual choice, and that was causing reduced torque when in the band below the rated frequency. This system was made to improve the generation torque of the motor by calculating a new V/f ratio with a new algorithm. This allowed to obtain flat high torque characteristic from stop state to the rated speed. As a result, since depression of a torque curve was disappeared in more wide-ranging frequency, we are able to get the driver and the motor with wide application range. Fig. 3 shows an example of the torque characteristic.

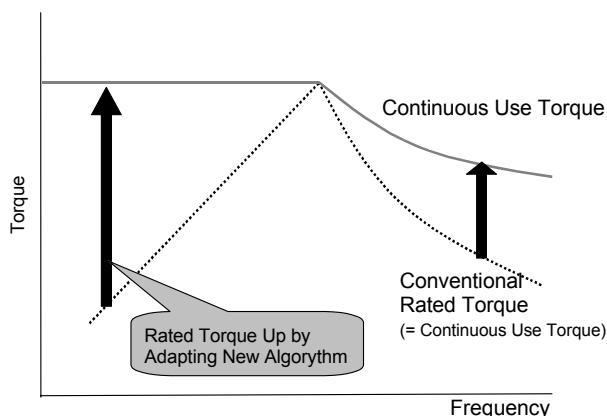

Fig. 3 Generation Torque

#### 4.4 Improved Rated Speed

Although the output frequency range of the driver is usually able to output within a range of approximately 0-400Hz, the torque curve in the frequency band of 60Hz or more is decreased rapidly because our synchronous motor (standard type) has been designed for use in the proximity to power supply frequency (50/60Hz). The high-speed type motor of this system has a design that enables high-speed rotation to output a steady torque of up to 120min<sup>-1</sup>.

#### 4.5 Occurrence of position retention function

Torque can be obtained even when stopping since our synchronous motor is designed based on the stepping motor. In the past, when a inverter equipment for running induction motor is used, the motor was free since the output voltage became 0 at a standstill. However, we have improved this system so that it will keep generating DC voltage with the parameter setting even at a standstill, by enhancing the function of the external DC braking terminal and turning on this terminal. It is now possible to use this system without using a mechanical brake for functions like locking the wheel of the cart, preventing a vertical axis from falling by its own weight, or simple positioning use, because torque can be obtained at a standstill. Mechanical brakes were surely needed in the system to occurrence of position retention if a inverter equipment for running induction motor is used. Use of this function will improve the cost of the machines and ease of maintenance without using a mechanical brake, and removes concern about deterioration caused by using of the brake or aging. Moreover, the throughput of the system can also be improved, because we don't have to wait until the mechanical brake is released (20ms-200ms).

The voltage value that is output for DC Braking is able to be set arbitrarily. This set voltage is output and enters DC Braking state if the external DC braking terminal has been turned on at a standstill. Moreover, when there is an operation command, the voltage is output regardless of the state of the external DC braking terminal ON/OFF, according to the V-F characteristic that is separately set. Fig. 4 is a time chart of the external DC braking terminal and the DC braking. (Patent pending)

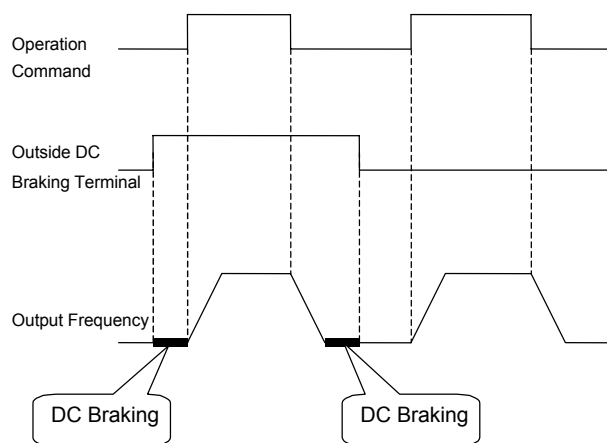

Fig. 4 Outside DC Braking Time Chart

#### 4.6 A single driver can synchronize and control multiple motors

This system can drive two or more motors with one driver. Synchronous operation of more than one motor is possible simply by connecting three phase power supply output from the driver to the motors, because the synchronous motor is designed based on a stepping motor. Attention needs to be paid only to the total rated current value of the motor, to ensure it doesn't exceed that of the driver. Fig. 5 shows an example.

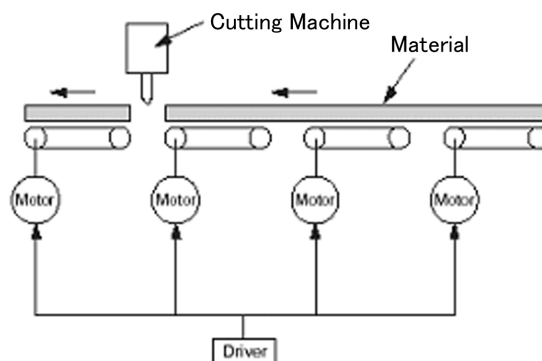

Fig. 5 Example of Cutting Machine

### 4.7 Outside Connecting Diagram

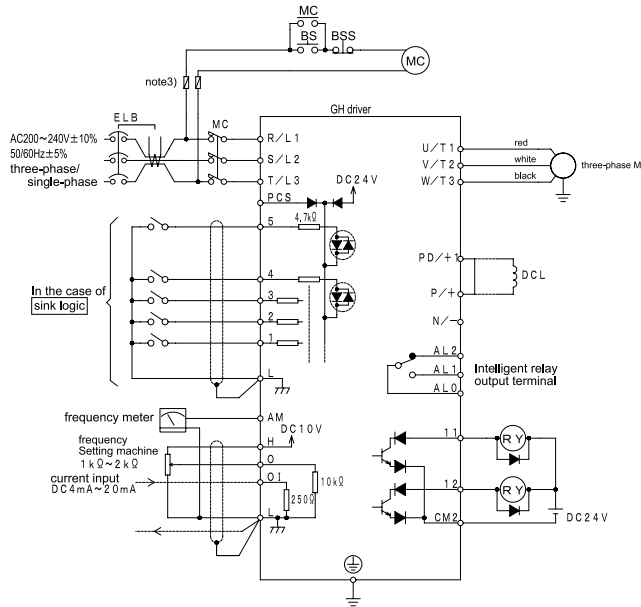

Fig. 6 Outside Connecting Diagram

### 4.8 Driver External Views

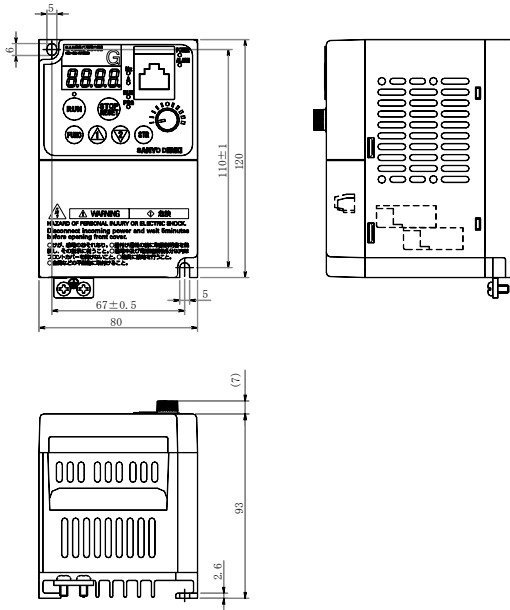

Fig. 7 Driver Outside Views

## 5. Example of Synchronous Motor Application

With our synchronous motor, low speed and high torque is obtained without using the reduction gear, since it is a super multi-pole motor based on a stepping motor. It is therefore used as a cylinder driving motor in a cryocooler, in the compression machine of refrigerative gas, or as a driving motor in transportation equipment such as conveyers and cart. Fig. 8 shows an example of use in a cryo pump.

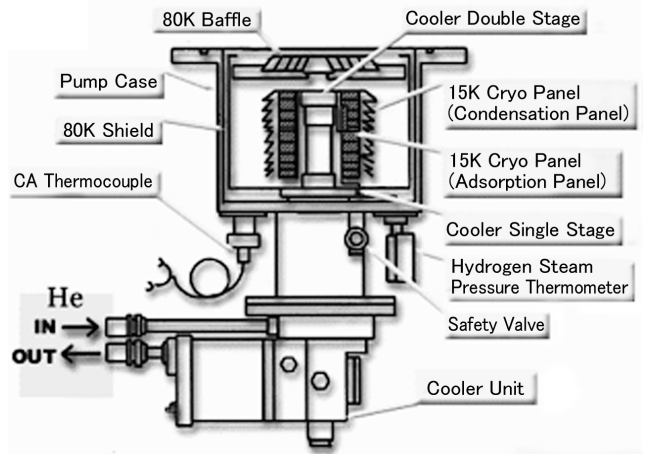

Fig. 8 Example in Cryo Pump

A cryocooler, which is used for a cryo pump, has been designed to use commercial power supply. Its operating method is to drive constantly irrespective of the status of the device to be cooled, because it is used only to control ON/OFF switching, and power consumption was also constant. Moreover, the freezing ability of the cooler was also constant. Given the recent focus on preserving the environment and reducing costs, the further increase in efficiency of a motor and a drive system is an important subject. It is believed that approximately half of the electric energy produced is consumed after it is converted into machine energy by an actuator such as a motor.

Though the freezing ability and the energy savings of the cryocooler have been improved with the inverter technology, when a inverter equipment for running induction motor is used with speed control of the synchronous motor, the motor sometimes goes out of synch because of insufficient torque generated in the band below the rated frequency. Adopting the new drive system realizes energy saving and highly effective cooling devices without step-out.

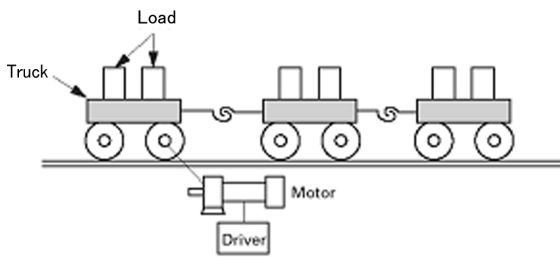

Fig.9 Example in Running Truck

The example of use in a running truck is shown in Fig. 9. Again in this example, the inverter technology contributes to the running stability as in the energy saving and the smooth starting. Because the new drive system has a flat torque characteristic from stop state to the rated speed, the motor can be smaller. Moreover, low speed can be obtained without using the reduction gear, and the structure of the device can be simpler. Additionally, the weight and the cost of the device can be reduced even further, since even a mechanical brake is unnecessary in such conveyer and a such curt device that wants to occurrence of position retention.

## 6. Conclusion

System SANMOTION G, which used the synchronous motor we have developed and the driver, was able to obtain a steady torque for rotating speeds from low to high ( $120\text{min}^{-1}$ ) as well as characteristics that were not able to be achieved previously with a combination with a general-purpose inverter. When a inverter equipment for running induction motor is used, many customer often use the reduction gear in order to improve the torque in the band below the rated frequency.

We are now able to propose a gearless system to such customer using SANMOTION G.

We believe that a gearless system offers the user a number of advantages, such as reduced cost and improved maintainability.

The occurrence of position retention function enabled easy positioning. Thereby, this expanded the use of SANMOTION G.

We will continue to provide timely products corresponding to customer needs.



### Shigeki Satou

Joined company in 1984  
Servo Systems Div., 4th Design Dept.  
Worked on design and development of system product



### Yoshinori Kimura

Joined company in 1985  
Servo Systems Div., 4th Design Dept.  
Worked on design and development of system product



### Shigenori Miyairi

Joined company in 1990  
Servo Systems Div., 3rd Design Dept.  
Worked on design and development of stepping motor



### Koji Nakatake

Joined company in 2001  
Servo Systems Div., 3rd Design Dept.  
Worked on design and development of stepping motor